

HYUNDAI
POWER PRODUCTS

VIBRATORY PLATE COMPACTOR

MODEL: HCOMP200-2

ORIGINAL INSTRUCTIONS

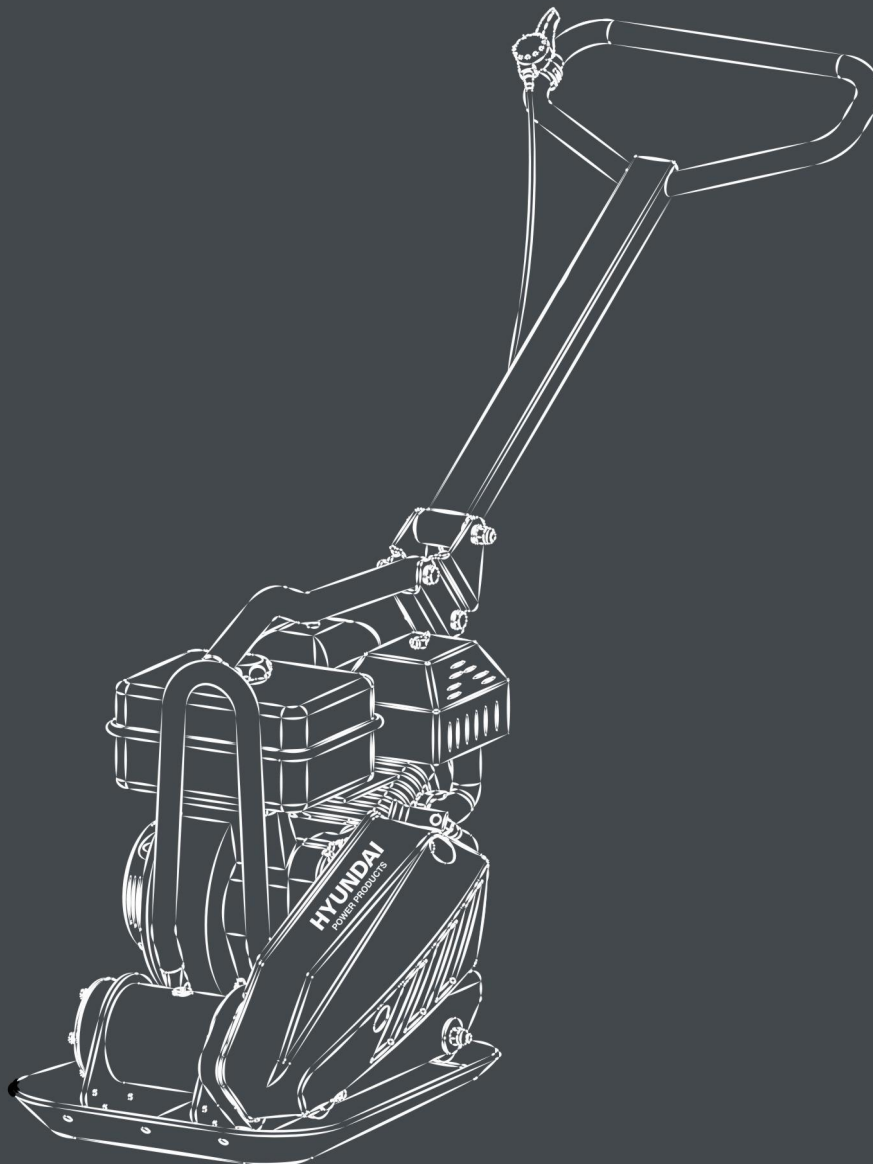

CONTENTS

1. SAFETY WARNING	3
2. ABOUT YOUR PRODUCT	7
3. ASSEMBLY	10
4. USE	13
5. MAINTENANCE	15
6. STORAGE	20
7. LIFT AND TRANSPORT	22
8. TROUBLE SHOOTING	23
9. DECLARATION OF CONFORMITY	24

1. SAFETY WARNINGS

General Safety Rules

a) Understand your Machine

- Read and understand the operator's manual and labels affixed to the machine. Learn its application and limitations as well as the specific potential hazards peculiar to it.
- Be thoroughly familiar with the controls and their proper operation. Know how to stop the machine and disengage the controls quickly.
- Make sure to read and understand all the instructions and safety precautions as outlined in the Engine Manual, packed separately with your unit. Do not attempt to operate the machine until you fully understand how to properly operate and maintain the Engine and how to avoid accidental injuries and/or property damage.

b) Work area

- Never start or run the engine inside a closed area. The exhaust fumes are dangerous, containing carbon monoxide, an odorless and deadly gas. Operate this unit only in a well ventilated outdoor area.
- Never operate the machine without good visibility or light.

c) Personal safety

- Do not operate the machine while under the influence of drugs, alcohol, or any medication that could affect your ability to use it properly.
- Dress properly. Wear heavy long pants, boots and gloves. Do not wear loose clothing, short pants, jewelry of any kind. Secure long hair so it is above shoulder level. Keep your hair, clothing and gloves away from moving parts. Loose clothes, jewelry or long hair can be caught in moving parts.
- Check your machine before starting it. Keep guards in place and in working order. Make sure all nuts, bolts, etc. are securely tightened.
- Never operate the machine when it is in need of repair or is in poor mechanical condition. Replace damaged, missing or failed parts before using it. Check for fuel leaks. Keep the machine in safe working condition.
- Do not use the machine if the engine's switch does not turn it on or off. Any gasoline powered machine that can not be controlled with the engine switch is dangerous and must be replaced.
- Form a habit of checking to see that keys and adjusting wrenches are removed from machine area before starting it. A wrench or a key that is left attached to a rotating part of the machine may result in personal injury.
- Stay alert, watch what you are doing and use common sense when operating the machine.
- Do not overreach. Do not operate the machine while barefoot or when wearing sandals or similar lightweight footwear. Wear protective footwear that will protect your feet and improve your footing on slippery surfaces. Keep proper footing and balance at all times. This enables better control of the machine in unexpected situations.
- Avoid accidental starting. Be sure the engine's switch is off before transporting the machine or performing any maintenance or service on the unit. Transporting or performing maintenance or service on a machine with its switch on invites accidents.

d) Fuel safety

- Fuel is highly flammable, and its vapors can explode if ignited. Take precautions when using to reduce the chance of serious personal injury.
 - When refilling or draining the fuel tank, use an approved fuel storage container while in a clean, well-ventilated outdoor area. Do not smoke, or allow sparks, open flames or other sources of ignition near the area while adding fuel or operating the unit. Never fill fuel tank indoors.
 - Keep grounded conductive objects, such as tools, away from exposed, live electrical parts and connections to avoid sparking or arcing. These events could ignite fumes or vapors.
 - Always stop the engine and allow it to cool before filling the fuel tank. Never remove the cap of the fuel tank or add fuel while the engine is running or when the engine is hot. Do not operate the machine with known leaks in the fuel system.
 - Loosen the fuel tank cap slowly to relieve any pressure in the tank.
 - Never overfill fuel tank (there should be no fuel above the upper limit mark).
 - Replace all fuel tank and container caps securely and wipe up spilled fuel. Never operate the unit without the fuel cap securely in place.
 - Replace all fuel tank and container caps securely and wipe up spilled fuel. Never operate the unit without the fuel cap securely in place.
 - Avoid creating a source of ignition for spilled fuel. If fuel is spilled, do not attempt to start the engine but move the machine away from the area of spillage and avoid creating any source of ignition until fuel vapors have dissipated.
 - Store fuel in containers specifically designed and approved for this purpose.
 - Store fuel in a cool, well-ventilated area, safely away from sparks, open flames or other sources of ignition.
 - Never store fuel or machine with fuel in the tank inside a building where fumes may reach an spark, open flame, or any other source of ignition, such as a water heater, furnace, clothes dryer and the like. Allow the engine to cool before storing in any enclosure.
- e) Machine use and care
- Never pick up or carry a machine while the engine is running.
 - Do not force the machine. Use the correct machine for your application. The correct machine will do the job better and safer at the rate for which it was designed.
 - Do not change the engine governor settings or over-speed the engine. The governor controls the maximum safe operating speed of the engine.
 - Do not run the engine at a high speed when you are not pounding.
 - Do not put hands or feet near rotating parts.
 - Avoid contact with hot fuel, oil, exhaust fumes and hot surfaces. Do not touch the engine or muffler. These parts get extremely hot from operation. They remain hot for a short time after you turn off the unit. Allow the engine to cool before doing maintenance or making adjustments.
 - If the machine should start to make an unusual noise or vibration, immediately shut off the engine, disconnect the spark plug wire, and check for the cause. Unusual noise or vibration is generally warning of trouble.
 - Use only attachments and accessories approved by the manufacturer. Failure to do so can result in personal injury.
 - Maintain the machine. Check for misalignment or binding of moving parts, breakage of parts and any other condition that may affect the machine's operation. If damaged, have

the machine repaired before use. Many accidents are caused by poorly maintained equipment.

- Keep the engine and muffler free of grass, leaves, excessive grease or carbon build up to reduce the chance of a fire hazard.
- Never douse or squirt the unit with water or any other liquid. Keep handles dry, clean and free from debris. Clean after each use.
- Observe proper disposal laws and regulations for gas, oil, etc. to protect the environment.
- Store idle machine out of the reach of children and do not allow persons unfamiliar with the machine or these instructions to operate it. Machine is dangerous in the hands of untrained users.

f) Service

- Before cleaning , repair , inspecting , Or adjusting, shut off the engine and make certain all moving parts have stopped. Always make sure the engine's switch is in its "OFF" position. Disconnect the spark plug wire, and keep the wire away from the plug to prevent accidental starting.
- Have your machine serviced by a qualified repair personnel using only identical replacement parts. This will ensure that the safety of the machine maintained.

Specific Safety Rules

- To avoid injury, keep hands, fingers and feet away from the base plate. Grip the handle of the plate compactor firmly with both hands. If both hands are holding the handle and your feet are clear of the compactor base, your hands, fingers and feet can not be injured by the compactor base.
- Always operate the machine from behind, never pass or stand in front of the machine when the engine is running.
- Never place tools or any other item under the plate compactor.
- If the unit strikes a foreign object, stop the engine, disconnect the spark plug, thoroughly inspect the machine for any damage, and repair the damage before restarting and operating the machine.
- Do not overload the machine capacity by compacting too deep in a single pass or at too fast a rate.
- Never operate the unit at high transport speeds on hard or slippery surfaces.
- Exercise extreme caution when operating on or crossing gravel drives, walks, or roads. Stay alert for hidden hazards or traffic. Do not carry passengers.
- Never leave the operating position and leave the plate compactor unattended when the engine is running.
- Always stop the engine when compacting is delayed or when walking from one location to another.
- Stay away from the edged of ditches and avoid actions that may cause the plate compactor to topple over.
- Always ascend slopes carefully, in a direct path and in reverse to prevent the plate compactor from toppling over onto the operator.
- Always park the unit on a firm and level surface and shut the tool off.
- To reduce exposure to vibration, limit the hours of operation and take periodic breaks to minimize repetition and rest your hand. Reduce the speed and force in which you do the repetitive movement. Try to fill each day with jobs where operating hand-held power equipment is not required.

SYMBOLS

	<p>Read these instructions for use carefully.</p>
	<p>Wear eye protection. Wear hearing protection.</p>
	<p>Wear protective gloves.</p>
	<p>Wear safety footwear.</p>
	<p>It is forbidden to remove or tamper with the protection devices and safety devices.</p>
	<p>Keep away from rotating parts.</p>
	<p>Do not touch parts which are hot from operation. Serious burns may result.</p>
	<p>Do not smoke or have open flames. Use extreme caution when storing, handling and using fuels, as they are highly volatile and explosive in vapor state.</p>
	<p>Keep children and bystanders off and away.</p>

2. ABOUT YOUR PRODUCT

Your new Vibratory Plate Compactor will more than satisfy your expectations. It has been manufactured under stringent quality standards to meet superior performance criteria. You will find it easy and safe to operate, and with proper care, it will give you many years of dependable service.



Carefully read through this entire operator's manual before using. Take special care to heed the cautions and warnings.

The commitment to quality has been designed into details: reinforced self-cleaning base plate, engine oil drain hose, closed V-belt guard, self-adjusting centrifugal clutch and folding handle. A range of useful accessories enables use in all kinds of applications.

The Plate Compactor applies energy to the loose soil or other materials to increase its density and load bearing capacity, mainly used for small repair and maintenance work. The loose soil or particles are moved or rearranged in a particular manner close to each other to avoid any trapped air or voids. It increases the load bearing capacity, decreases water seepage, prevents soil settlement, reduces swelling, contraction of the soil and prevents frost damage. It is ideal for compaction of granular soils, sands, gravel, crushed aggregate and mixed soils.



These compactors are not intended to be used on cohesive soils such as clay or hard surfaces like concrete.

The Engine Manufacturer is responsible for all engine-related issues with regards to performance, power rating, specifications, warranty and service. Please refer to the Engine Manufacturer's owner/operator's manual, packed separately with your unit, for more information.

Product description

- | | |
|---------------------|---|
| 1. Throttle Control | 7. Muffler |
| 2. Lift Handle | 8. Oil Drain Hose |
| 3. Air Cleaner | 9. Belt Guard |
| 4. Fuel Tank | 10. Base Plate |
| 5. Base Plate | 11. Foldings Wheels
Bracket(Optional) |
| 6. Handle | 12. Wheels(Optional) |

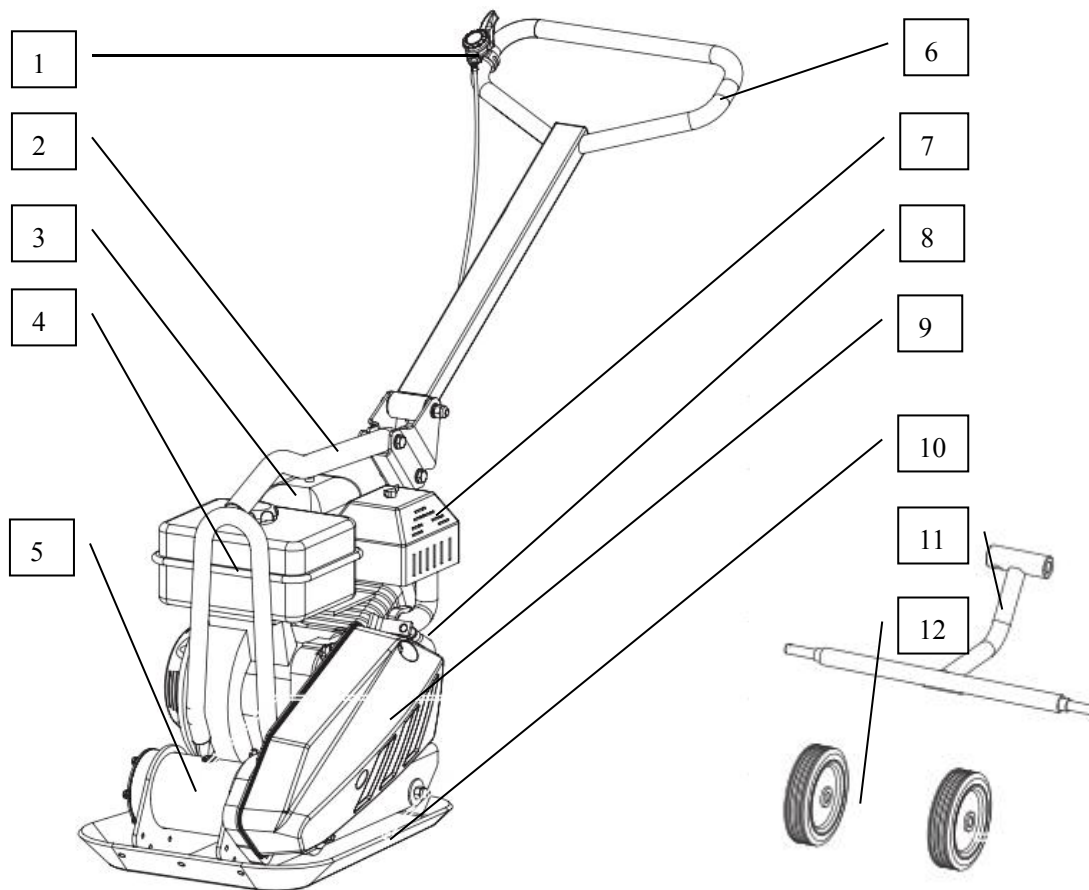

Fuel Valve Control

The fuel valve opens and closes the passage between the fuel tank and the carburetor. The fuel valve lever must be in the ON position for the engine to run. When the engine is not in use, leave the fuel valve lever in the OFF position to prevent carburetor flooding and to reduce the possibility of fuel leakage.

Throttle Control

The throttle lever controls engine speed. Moving the throttle lever makes the engine run faster or slower.

Engine Switch

The engine switch enables and disables the ignition system. The engine switch must be in the ON position for the engine to run. Turning the engine switch to the OFF position stops the engine.

Choke Lever

The choke lever opens and closes the choke valve in the carburetor. The closed position enriches the fuel mixture for starting a cold engine. The open position provides the correct fuel mixture for operation after starting, and for restarting a warm engine. Some engine applications use a remotely-mounted choke control rather than the engine-mounted choke lever.

Recoil Starter Grip

Pulling the starter grip operates the recoil starter to crank the engine.

Oil Drain Hose

Running the engine with dirty oil can cause premature engine wear and failure. Changing oil regularly is extremely important. The flexible oil drain hose is equipped to drain oil into appropriate receptacle.

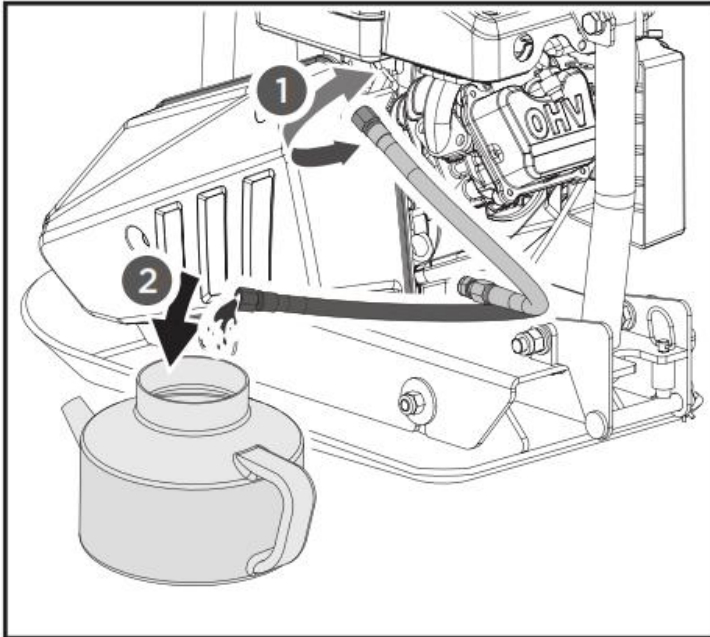

Exciter

An eccentric weight mounted on the exciter shaft contained within exciter housing is driven at high speed by a clutch and belt drive system. This high speed shaft revolution causes the rapid lifting and downward ramming motion of the machine as well as imparting a forward motion.

Specifications

Model	HCOMP200-2
Plate Size	520 X 445 mm
Centrifugal Force	13000 N
Exciter Speed	5500/min
Compaction depth	30 cm
Travel Speed	15 m/min
Engine	4.1kW (196cc)
Operation Weight	79 kg
Sound power level measured	99.0dB(A),K=2.26 dB(A)
Guarantee Sound power level	103dB(A)
Vibration value	15.6m/s ² , K=1.5m/s ²

3. ASSEMBLY

- a) Mount the handle to the chassis with the M10X95 bolt, washers and nut.

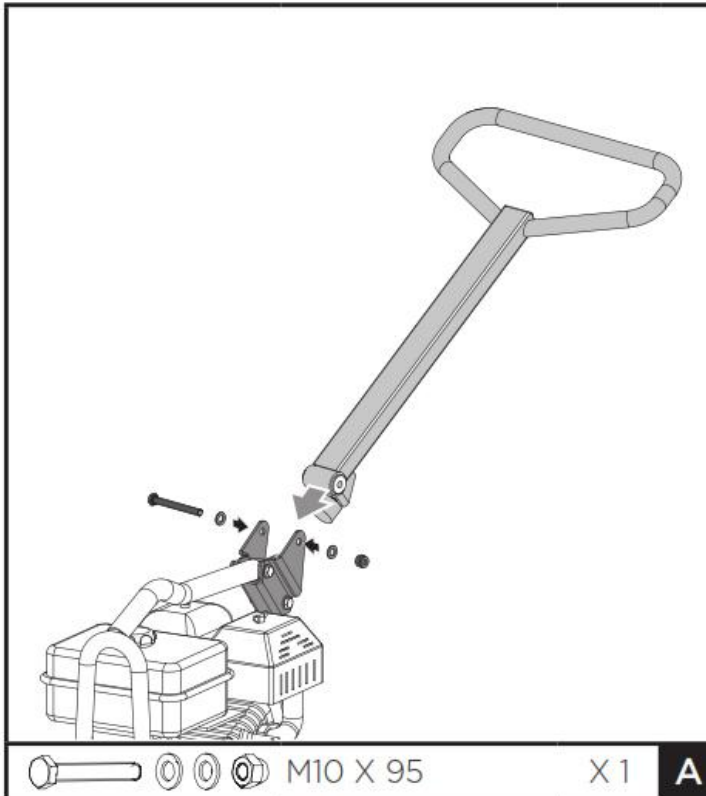

- b) Fix the throttle control to the upper handle as shown.

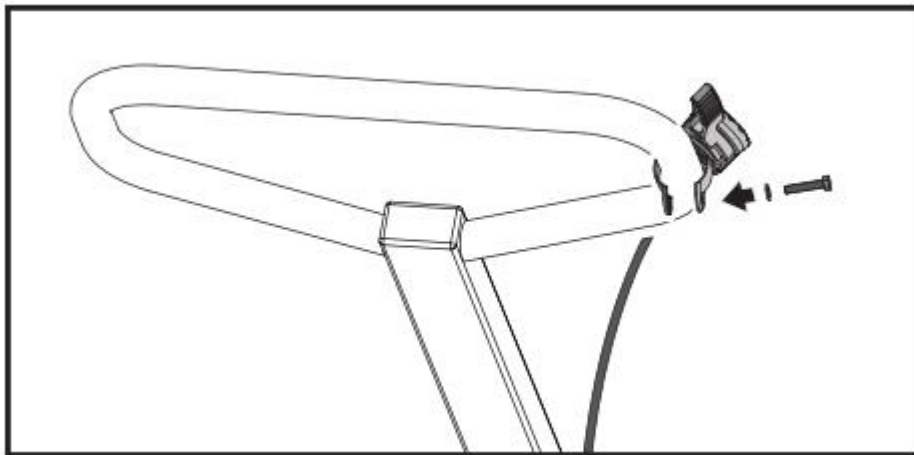

- c) Folding Wheels Kit
- i. Slide the wheels over the stub axles. Secure with hairpin retainers and flat washers.

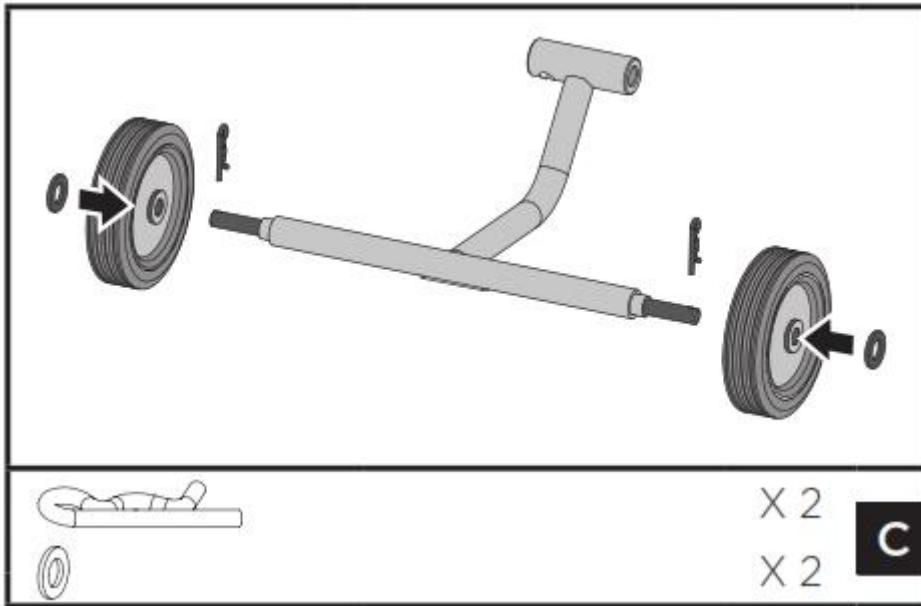

- ii. Three holes on the stub axle allow to adjust the distance between the wheels, pull out the pin first, adjust the wheels to the suitable distance, then tighten with the pin.

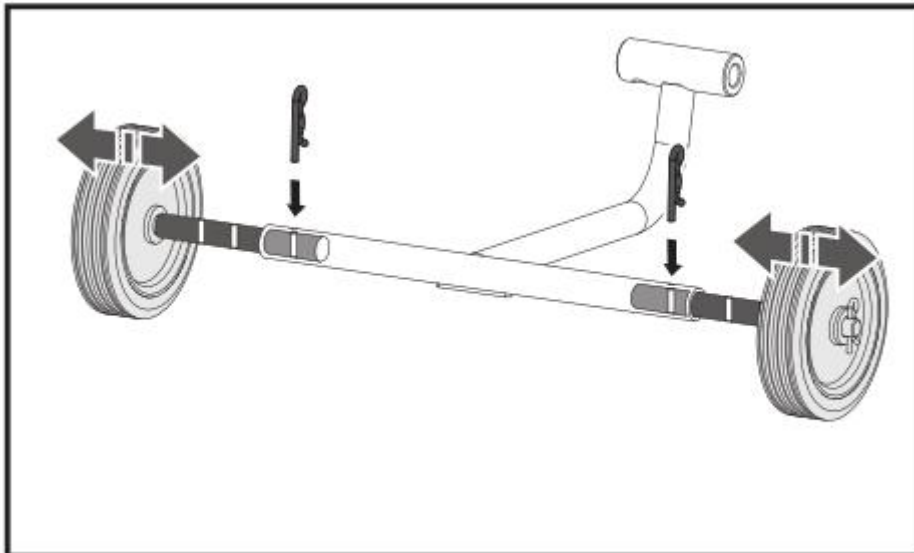

- iii. Pull up the spring bolt and put the upper pipe of the wheels bracket into the mounting bracket. Align two ends of the pipe with the holes. Slide the bolt in and secure with the clips.

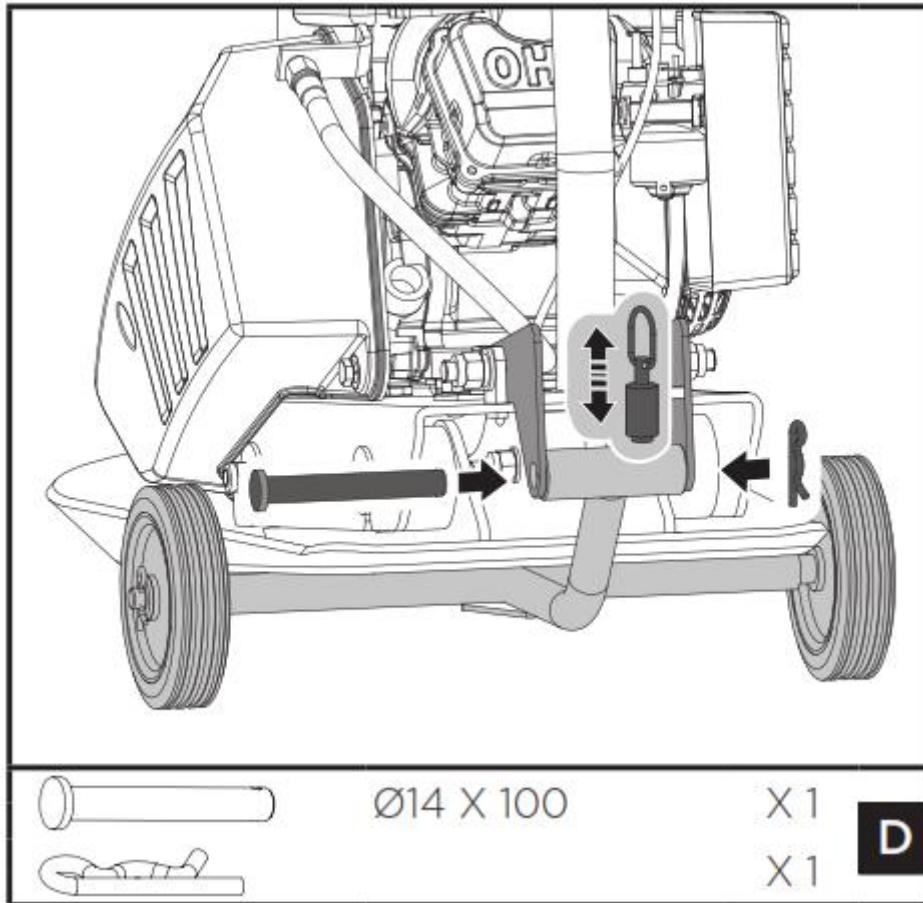

d) Engine Oil



OIL HAS BEEN DRAINED FOR SHIPPING!

Failure to fill engine sump with oil before starting engine will result in permanent damage and void engine warranty.

Add oil according to Engine Manual.

4. USE

- a) Adding fuel:
 - i. Fill the fuel tank as instructed in the separate Engine Manual;
 - ii. More detailed description of the engine operation and all related precautions and procedures can be found in the Engine Manual packed separately with the unit.
- b) Starting Engine
 - i. Move the fuel valve lever to the “ON” position.
 - ii. To start a cold engine, move the choke to the CLOSE position. To restart a warm engine, leave the choke lever in the OPEN position.
 - iii. Move the throttle lever away from the SLOW position, about 1/3 of the way toward the FAST position.
 - iv. Turn the engine switch to the ON position.
 - v. Operate the starter.
- c) Operating



Do not operate plate on concrete or on extremely hard, dry, compacted surfaces. The plate will jump rather than vibrate and could damage both plate and engine.

- i. After engine warms up, pull throttle lever to accelerate engine speed. Plate will begin vibrating and move forward.
- ii. The plate compactor is designed to run at an engine speed (engine take off shaft) of 3600 rpm (Normally considered full throttle). Running the engine at lower rpm's will result in a decrease of compaction force and lower travel speed. It will create excessive “out-of-synch” vibrations resulting in poor compaction, maneuverability, excessive wear to the machine, and discomfort to the operator.
- iii. In operation, guide the machine, but let the compactor do the work. Bearing down on the handle is unnecessary and causes shock absorber wear.
- iv. On level surfaces the compactor moves forward rapidly. On uneven surfaces or inclines, light forward pressure on handle may be required to assist the compactor in moving forward.
- v. The number of passes required to reach a desired compaction level will depend on the type and moisture content of soil. Maximum soil compaction has been reached when excessive kickback is noticed.
- vi. **When using a compactor on asphalt, Water Sprinkler Kit is required to help prevent the bottom plate from adhering to the hot asphalt surface.**
- vii. **When using plate on paving stones, attach a pad to the bottom of the plate to prevent chipping or grinding surface of the stones. A special urethane pad designed for this purpose is available as an optional accessory.**

- viii. While a certain amount of moisture in the soil is necessary, excessive moisture may cause soil particles to stick together and prevent good compaction. If soil is extremely wet, allow it to dry somewhat before compacting.
 - ix. If soil is so dry as to create dust clouds while operating plate, some moisture should be added to the ground material to improve compacting. This will also reduce service to the air filter.
- d) Stopping Engine
- To stop the engine in an emergency, simply turn the engine switch to the OFF position. Under normal conditions, use the following procedure.
- i. Move the throttle lever to the SLOW position.
 - ii. Let engine idle for one or two minutes.
 - iii. Turn the engine switch to the OFF position.
 - iv. Turn the fuel valve lever to the OFF position.



Do not move choke control to CLOSE to stop engine. Backfire or engine damage may occur.

- e) Idle Speed
- Set throttle control lever to its “low” position to reduce stress on the engine when compacting is not being performed. Lowering the engine speed to idle the engine will help extend the life of the engine, as well as conserve fuel and reduce the noise level of the machine.

5. MAINTENANCE

a) Preventive Maintenance

- i. Turn off engine. Engine must be cool.
- ii. Keep the engine's throttle lever in its SLOW position, and remove spark plug wire from spark plug and secure.
- iii. Inspect the general condition of the plate compactor. Check for loose screws, misalignment or binding of moving parts, cracked or broken parts, and any other condition that may affect its safe operation.
- iv. Remove all debris from the plate compactor with a soft brush, vacuum, or compressed air. Then use a premium quality lightweight machine oil to lubricate all moving parts.
- v. Clean the bottom of the compactor base as soon as it begins to pick up soil being compacted. The unit can not do a good job if the bottom surface is not smooth and clean.
- vi. Replace spark plug wire.



Never use a “pressure washer” to clean your plate compactor.

Water can penetrate tight areas of the unit and cause damage to spindles, pulleys, bearings, or the engine. The use of pressure washers will result in shortened life and reduce serviceability.

b) Checking V-Belt(s)

To ensure optimum power transmission from the engine to the eccentric shaft, the V-belt(s) must be in good condition and operate under proper tension.

- i. Turn off engine. Engine must be cool.
- ii. Remove the belt guard to access the V-belt(s).
- iii. Check the condition of the V-belt(s). If any V-belt is cracked, frayed, or glazed, it should be replaced as soon as convenient.
- iv. Check the V-belt tension by squeezing them in the center. The normal deflection on each side should be 9mm (3/8” to 13mm (1/2” with moderate pressure from your thumb or finger.



On new machines or after installing a new belt, check belt tension after first 20 hours of operation. Check and adjust belt every 50 hours thereafter.

c) Tensioning V-Belt(s)

Proper belt tension is critical to good performance.

Proper adjustment will assure long belt life. Too much or too little belt tension will cause premature belt failure.

- i. Loosen the jam nuts B, leaving enough space between the nut and bracket.

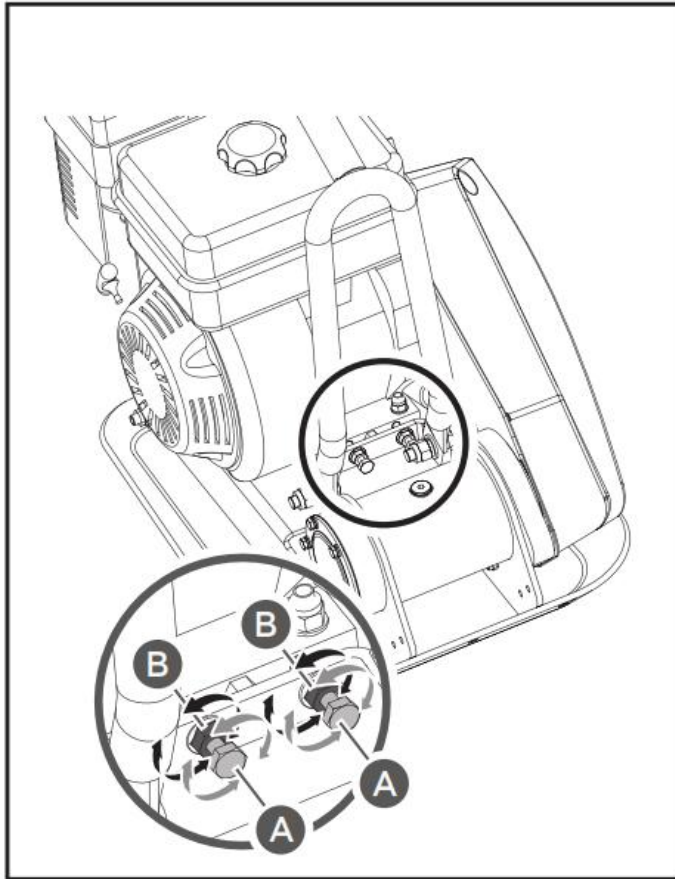

- ii. Push engine toward the back of the plate by turning the adjustment bolts A to remove any slack in V-belt(s).

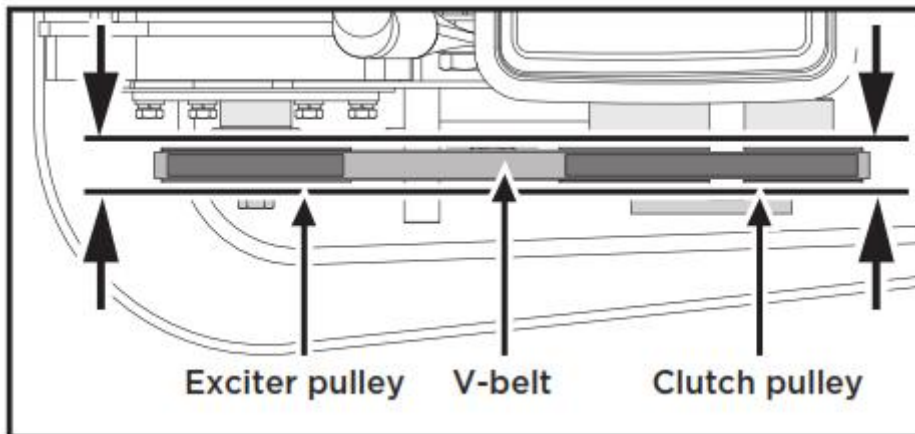

When adjusting the belt(s), make sure that the clutch pulley is in alignment with exciter pulley.

- iii. When the V-belt tension is correct, tighten the jam nuts B against the bracket.
- iv. Tighten the engine mount bolts.
- v. Replace the belt guard.

If the adjustment bolts have no more adjustment left, the belt(s) may have to be replaced.

d) Replacing V-Belt(s)

Both V-belts should be replaced at the same time because they will wear evenly through normal use. Work on one belt at a time.

- i. Loose 4 engine mount bolts (do not remove) only enough to move the engine forward.
- ii. Loosen the jam nuts B and bolts A shown in above figure.
- iii. Slide the engine toward the front of plate and slip the old V-belt(s) off of the wheel pulley and install the new V-belt(s) in their place.

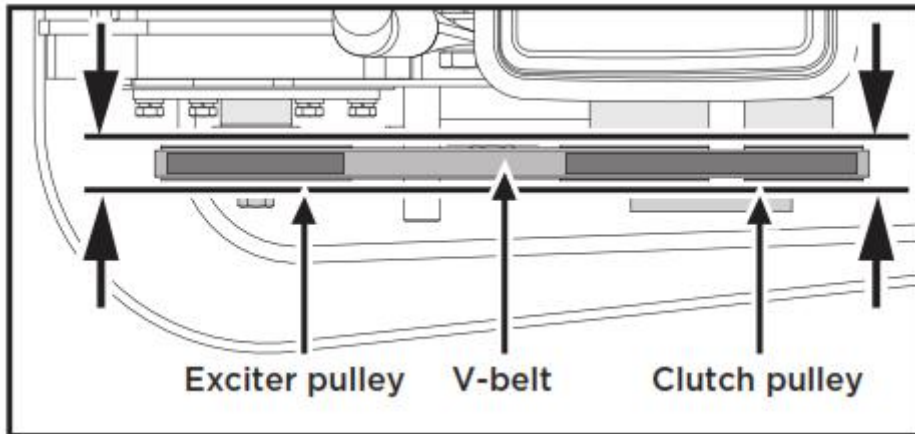

- iv. Position the V-belt(s) over the engine pulley.
- v. Move the engine back.



When adjusting the belt(s), make sure that the clutch pulley is in alignment with exciter pulley.

- vi. When the V-belt tension is correct, tighten the jam nuts B and the engine mount bolts.
- vii. Replace the belt guard.



When removing or installing the drive belt(s), be careful not to get your fingers caught between the belt and pulley.

e) Exciter Lubrication

The exciter housing is pre-serviced using Automatic Transmission Fluid Dextron III, Mercon, EXXON (ESSO) NUTO H-32 or its equivalent. Change fluid after 200 hours of operation.

- i. Let exciter cool before changing exciter oil.
- ii. Remove the belt guard and V-belt(s).

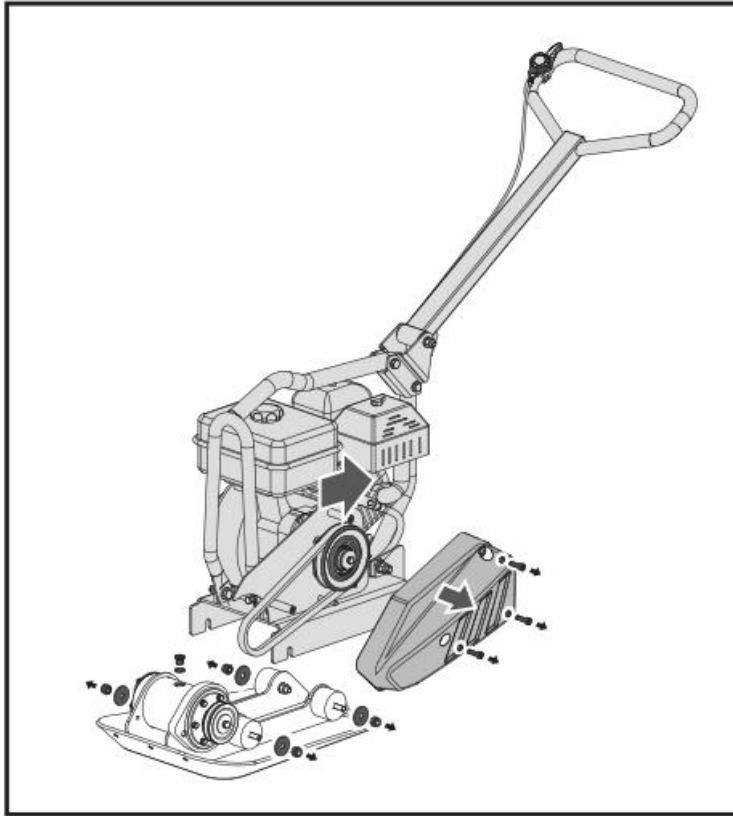

- iii. Remove the bolts that hold the deck to the housing.
- iv. Lift entire deck with engine from housing.
- v. Remove pipe plug from top of exciter housing. Tilt housing upside down so oil drains from exciter. Examine oil for metal chips as a precaution to future problems.

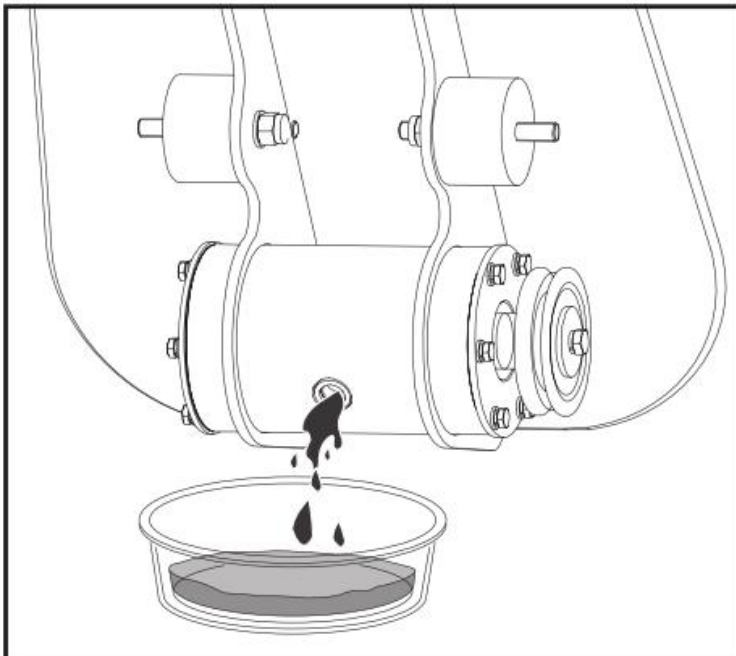

- vi. Return plate housing to the upright position.
- vii. Fill the exciter housing with exciter oil 140 ml

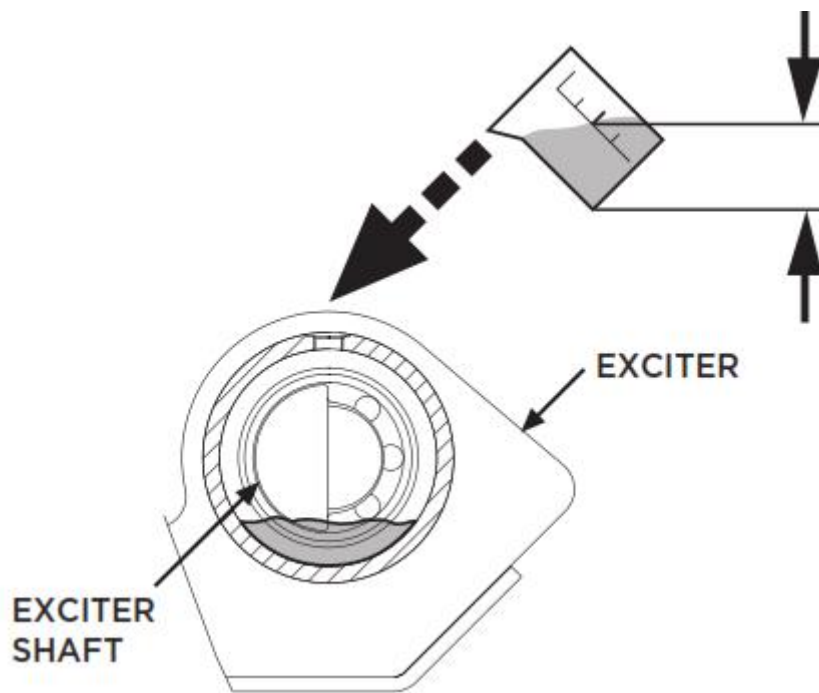

Do not overfill - overfilling can result in excessive temperatures in the exciter.

- viii. Apply pipe sealant to pipe plug and reinstall into top of exciter housing.
- ix. Reinstall deck, V-belt(s) and belt guard.

f) Engine maintenance

Refer to the Engine Manual included in your plate compactor for the information on engine maintenance. Your engine manual provides detailed information for performing the tasks.

6. STORAGE

If the plate compactor will not be used for a period longer than 30 days, following the steps below to prepare your unit for storage.

- 1) Drain the fuel tank completely. Stored fuel containing ethanol or MTBE can start to go stale in 30 days. Stale fuel has high gum content and can clog the carburetor and restrict fuel flow.
- 2) Start the engine and allow it to run until it stops. This ensures no fuel is left in the carburetor. Run the engine until it stops. This helps prevent deposits from forming inside the carburetor and possible engine damage.
- 3) While the engine is still warm, drain the oil from the engine. Refill with fresh oil of the grade recommended in the Engine Manual.
- 4) Allow the engine to cool. Remove the spark plug and put 60 ml of SAE-30 of high quality motor oil into the cylinder. Pull the starter rope slowly to distribute the oil. Replace the spark plug.



Remove the spark plug and drain all of the oil from the cylinder before attempting to start the unit after storage.

- 5) Use clean cloths to clean off the outside of the compactor and to keep the air vents free of obstructions.



Do not use strong detergents or petroleum based cleaners when cleaning plastic parts. Chemicals can damage plastics.

- 6) Pull up the spring bolt and fold up the wheels bracket.

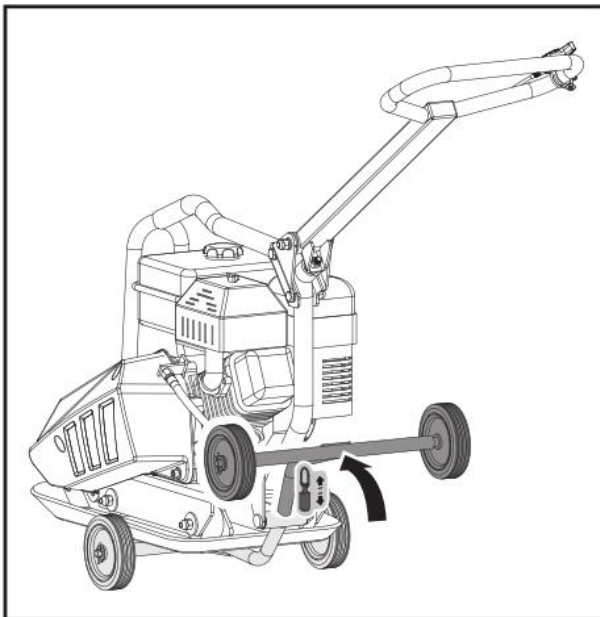

- 7) Carefully fold the handle down. Do not allow control cables to become pinched or bent.

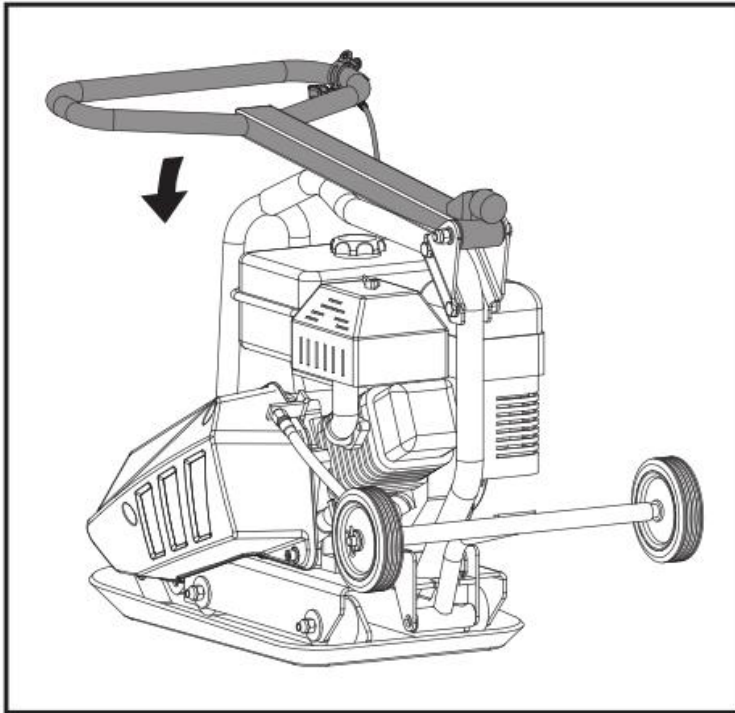

- 8) Store your plate compactor in upright position in a clean, dry building that has good ventilation.

7. LIFT AND TRANSPORT

See technical data for the weight of the machine.

To avoid burns or fire hazards, let engine cool before lifting / transporting machine or storing indoors.

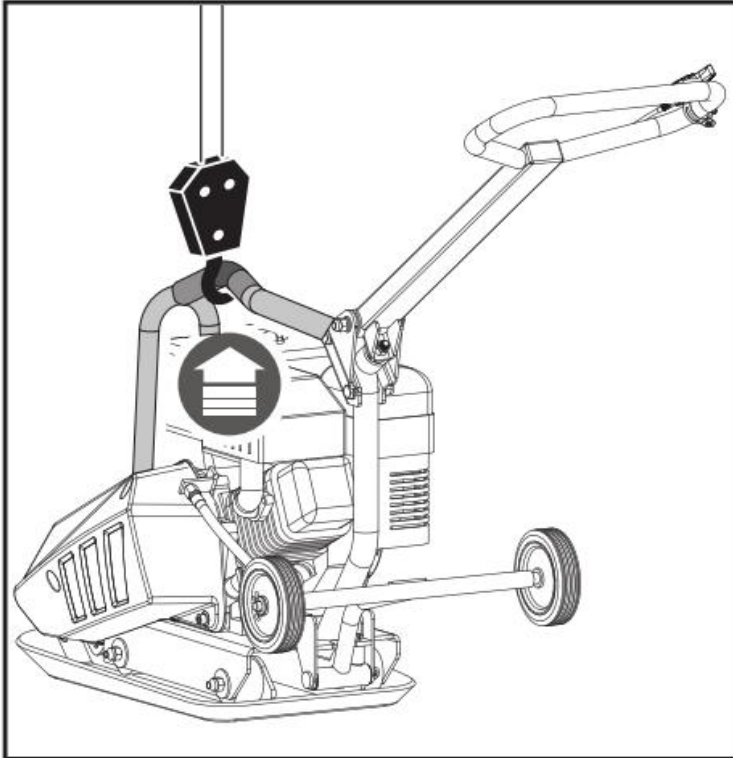

The unit must be transported in the upright position to prevent fuel from spilling. Do not lay machine on its side or top.

Secure or tie down unit using the lifting handle to prevent machine from sliding or tipping over.



Machine may fall and cause damage or injury if lifted incorrectly. Lift using handles at base of plate.

8. TROUBLE SHOOTING

Problem	Cause	Remedy
Engine fails to start.	<ol style="list-style-type: none"> 1) Spark plug wire disconnected. 2) Out of fuel or stale fuel 3) Throttle control lever not in correct starting position. 4) Choke not in ON Position. 5) Blocked fuel line. 6) Fouled spark plug. 7) Engine flooding. 	<ol style="list-style-type: none"> 1) Attach spark plug wire securely to spark plug. 2) Fill with clean, fresh gasoline. 3) Move throttle control lever to start position. 4) Throttle must be positioned at choke for a cold start. 5) Clean the fuel line. 6) Clean, adjust gap, or replace. 7) Wait a few minutes to restart, but do not prime.
Engine runs erratically.	<ol style="list-style-type: none"> 1) Spark plug wire loose. 2) Unit running on CHOKE. 3) Blocked fuel line or stale fuel. 4) Vent plugged. 5) Water or dirt in fuel system. 6) Dirty air cleaner. 	<ol style="list-style-type: none"> 1) Connect and tighten spark plug wire. 2) Move choke lever to OFF. 3) Clean fuel line. Fill tank with clean, fresh gasoline. 4) Clear vent. 5) Drain fuel tank. Refill with fresh fuel. 6) Clean or replace air cleaner.
Engine overheats.	<ol style="list-style-type: none"> 1) Engine oil level low. 2) Dirty air cleaner. 3) Air flow restricted. 	<ol style="list-style-type: none"> 1) Fill crankcase with proper oil. 2) Clean air cleaner. 3) Remove blower housing and clean.
Engine will not stop when throttle control is positioned at stop, or engine speed does not increase properly when throttle control is adjusted.	Debris interfering with throttle linkage.	Clean dirt and debris.
Compactor is difficult to control when pounding (machine jumps or lurches forward)	Too high engine speed on hard ground.	Set the throttle lever at lower speed.

9. CE DECLARATION OF CONFORMITY



EC Declaration of conformity

BUIDLER SAS

32, rue Aristide Bergès - ZI 31270 Cugnaux – France
declare that the machine

Designation: VIBRATORY PLATE COMPACTOR
(for applying energy to the loose soil or other materials
to increase its density and load bearing capacity)

Model: HCOMP200-2

Serial number: 20200910749-20200910856

The person is responsible for the technical file in EU: Olivier Patriarca
Is in conformity with the European Directives:

Machine Directive 2006/42/EC

EMC directive 2014/30/EU

Noise directive 2000/14/EC Annex VI & 2005/88/EC

Directive (EU) 2016/1628, amended by directive 2018/989

Measured sound power level: 99dB(A), K=2.26dB(A)

Guaranteed: 103dB(A);

Noise certificate was issued by Notified Body (NB no. 0036):

TÜV SÜD Industrie Service GmbH

This product is also in conformity with the following standards:

EN 500-4: 2011

EN 12100:2010, EN 55014-1:2017,

EN 61000-3-2:2014, EN 61000-3-3:2013, EN 55014-2:2015

Philippe MARIE / PDG

Cugnaux, le 15/07/2020

10. WARRANTY

HYUNDAI

WARRANTY

The manufacturer guarantees the product against defects in material and workmanship for a period of 2 years from the date of the original purchase. The warranty only applies if the product is for household use. The warranty does not cover breakdowns due to normal wear and tear.

The manufacturer agrees to replace parts identified as defective by the designated distributor. The manufacturer does not accept responsibility for the replacement of the machine, in whole or in part, and/or ensuing damage.

The warranty does not cover breakdowns due to:

- insufficient maintenance.
- abnormal assembly, adjustment or operations of the product.
- parts subject to normal wear and tear.

The warranty does not extend to:

- shipping and packaging costs.
- using the tool for a purpose other than that for which it was designed.
- the use and maintenance of the machine done in a manner not described in the user manual.

Due to our policy of continuous product improvement, we reserve the right to alter or change specifications without notice. Consequently, the product may be different from the information contained therein, but a modification will be undertaken without notice if it is recognized as an improvement of the preceding characteristic.

READ THE MANUAL CAREFULLY BEFORE USING THE MACHINE.

When ordering spare parts, please indicate the part number or code, you can find this in the spare parts list in this manual. Keep the purchase receipt; without it, the warranty is invalid. To help you with your product, we invite you to contact us by phone or via our website:

- **+33 (0)9.70.75.30.30**
- **<https://services.swap-europe.com/contact>**

You must create a "ticket" via the web platform.

- Register or create your account.
- Indicate the reference of the tool.
- Choose the subject of your request.
- Describe your problem.
- Attach these files: invoice or sales receipt, photo of the identification plate (serial number), photo of the part you need (for example: pins on the transformer plug which are broken).



11. PRODUCT FAILURE

WHAT TO DO IF MY MACHINE BREAKS DOWN?

If you bought your product in a store:

a) Empty the fuel tank.

b) Make sure that your machine is complete with all accessories supplied, and clean! If this is not the case, the repairer will refuse the machine.

Go to the store with the complete machine and with the receipt or invoice.

If you bought your product on a website:

a) Empty the fuel tank.

b) Make sure that your machine is complete with all accessories supplied, and clean! If this is not the case, the repairer will refuse the machine.

c) Create a SWAP-Europe service ticket on the site: <https://services.swap-europe.com> When making the request on SWAP-Europe, you must attach the invoice and the photo of the nameplate (serial number).

d) Contact the repair station to make sure it is available before dropping off the machine.

Go to the repair station with the complete machine packed, accompanied by the purchase invoice and the station support sheet downloadable after the service request is completed on the SWAP-Europe site

For machines with engine failure from manufacturers BRIGGS & STRATTON, HONDA and RATO, please refer to the following instructions.

Repairs will be done by approved engine manufacturers of these manufacturers, see their site:

- <http://www.briggsandstratton.com/eu/fr>
- <http://www.honda-engines-eu.com/fr/service-network-page;jsessionid=5EE8456CF39CD572AA2AEEDFD290CDAE>
- <https://www.rato-europe.com/it/service-network>

Please keep your original packaging to allow for after-sales service returns or pack your machine with a similar cardboard box of the same dimensions.

For any question concerning our after-sales service you can make a request on our website <https://services.swap-europe.com>

Our hotline remains available at +33 (9) 70 75 30 30.



12. WARRANTY EXCLUSIONS

THE WARRANTY DOES NOT COVER:

- Start-up and setting up of the product.
- Damage resulting from normal wear and tear of the product.
- Damage resulting from improper use of the product.
- Damage resulting from assembly or start-up not in accordance with the user manual.
- Breakdowns related to carburetion beyond 90 days and fouling of carburetors.
- Periodic and standard maintenance events.
- Actions of modification and dismantling that directly void the warranty.
- Products whose original authentication marking (brand, serial number) has been degraded, altered or withdrawn.
- Replacement of consumables.
- The use of non-original parts.
- Breakage of parts following impacts or projections.
- Accessories breakdowns.
- Defects and their consequences linked to any external cause.
- Loss of components and loss due to insufficient screwing.
- Cutting components and any damage related to the loosening of parts.
- Overload or overheating.
- Poor power supply quality: faulty voltage, voltage error, etc.
- Damages resulting from the deprivation of enjoyment of the product during the time necessary for repairs and more generally the costs related to the immobilization of the product.
- The costs of a second opinion established by a third party following an estimate by a SWAP-Europe repair station
- The use of a product which would show a defect or a breakage which was not the subject of an immediate report and/or repair with the services of SWAP-Europe.
- Deterioration linked to transport and storage*.
- Launchers beyond 90 days.
- Oil, petrol, grease.
- Damages related to the use of non-compliant fuels or lubricants.

* In accordance with transport legislation, damage related to transport must be declared to carriers within 48 hours maximum after observation by registered letter with acknowledgement of receipt.

This document is a supplement to your notice, a non-exhaustive list.

Attention: all orders must be checked in the presence of the delivery person. In case of refusal by the delivery person, it you must simply refuse the delivery and notify your refusal.

Reminder: the reserves do not exclude the notification by registered letter with acknowledgement within 72 hours.

Information:

Thermal devices must be wintered each season (service available on the SWAP-Europe site). Batteries must be charged before being stored.

HYUNDAI
POWER PRODUCTS

For Inquiries, please contact:

BUILDER SAS

32, rue Aristide Bergès Z1 31270 Cugnaux, France

Tél. : +33 (0) 5.34.502.502 Fax : +33 (0) 5.34.502.503

<http://www.hyundai-power-fr.com/>

Fabriqué en République Populaire de Chine (PRC)